

## Metric Socket Head Shoulder Screws, (Stripper Bolt), Manufactured in the USA

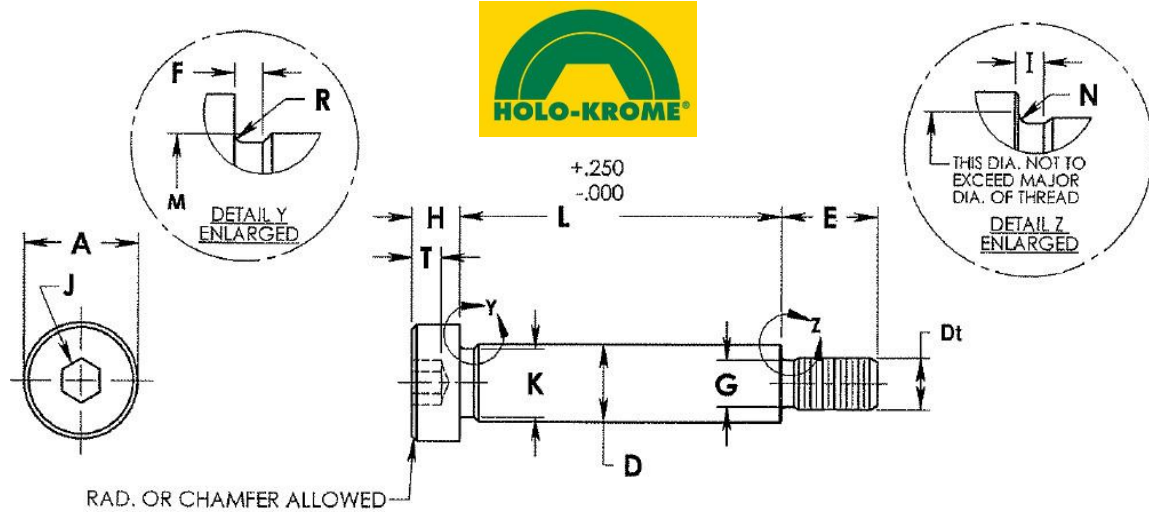

Nominal Screw Size or Basic Shoulder Dia.	D		A		H		J	T	M	R
	Shoulder Diameter		Head Diameter		Head Height		Hexagon Socket Size	Key Engagement	Head Fillet Extension Dia.	Shoulder Neck Fillet
	Max.	Min.	Max.	Min.	Max.	Min.	Nom.	Min.	Max.	Min.
6.0	6.00	5.982	10.00	9.78	4.50	4.32	3	2.4	6.8	0.25
8.0	8.00	7.978	13.00	12.73	5.50	5.32	4	3.3	9.2	0.40
10.0	10.00	9.978	16.00	15.73	7.00	6.78	5	4.2	11.2	0.40
12.0	12.00	11.973	18.00	17.73	9.00	8.78	6	4.9	14.2	0.60
16.0	16.00	15.973	24.00	23.67	11.00	10.73	8	6.6	18.2	0.60

Nominal Screw Size or Basic Shoulder Dia.	K	F	Dt		G		I	N	E	
	Shoulder Neck Dia.	Shoulder Neck Width	Basic Thread Diameter	Thread Pitch	Thread Neck Diameter		Thread Neck Width	Thread Neck Fillet Radius	Thread Length	
	Min.	Max.	Max.	Min.	Max.	Min.	Min.	Max.	Max.	Min.
6.0	5.42	2.5	M5	0.8	3.86	3.68	2.0	0.50	9.75	9.25
8.0	7.42	2.5	M6	1	4.58	4.40	2.5	0.53	11.25	10.75
10.0	9.42	2.5	M8	1.25	6.23	6.03	3.1	0.64	13.25	12.75
12.0	11.42	2.5	M10	1.5	7.89	7.66	3.7	0.77	16.40	15.60
16.0	15.42	2.5	M12	1.75	9.54	9.31	4.4	0.87	18.40	17.60

### Specification Requirements:

- Dimensions: See dimensions above.
- Threads: 4g6g
- Material: Alloy Steel
- Mechanical Properties: ISO 898-1 Class 12.9 per ISO 7379.
- Finish: Black Oxide (Thermal or Chemical) on un-ground surfaces.