

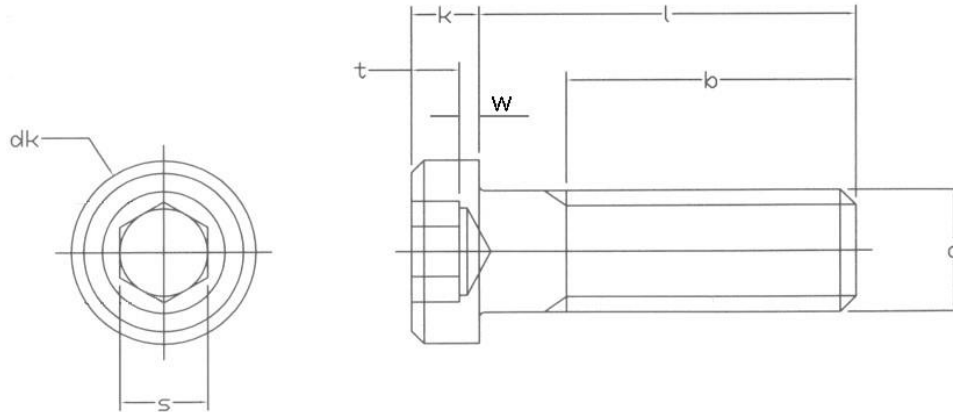

Low Head Socket Cap Screws, Metric, Black Oxide, Class 10.9, Manufactured in the USA



Diameter	dk		k		s	t	w
	Min.	Max.	Min.	Max.	Nom.	Min.	Min.
M4	6.78	7	2.66	2.8	3	1.48	1.06
M5	8.28	8.5	3.32	3.5	4	1.85	1.39
M6	9.78	10	3.82	4	5	2.09	1.65
M8	12.73	13	4.82	5	6	2.48	2.24
M10	15.73	16	6.32	6.5	8	3.36	2.86
M12	17.73	18	7.78	8	10	4.26	3.46
M16	23.67	24	9.78	10	12	4.76	4.91

### Specification Requirements:

- Dimensions: See dimensions above.
- Threads: 4g6g
- Material & Mechanical Properties: ISO 898-1 Class 10.9
- Marking: Manufacturer ID and Class "10.9"
- Finish: Black Oxide (Chemical or Thermal)
- Material Test Reports: The MTR must have documented lot traceability, including full chemical and mechanical figures, to the specification(s) above.