

CSK CRS TRITAP® THREAD FORMING SCREWS FOR METAL DIN 7500ME

Countersunk CRS tritap® thread forming screws for metal to DIN7500ME. The screws can be driven into malleable materials without the need for tapping the mating surfaces. A suitable pilot hole should be drilled using the below chart as guidance.

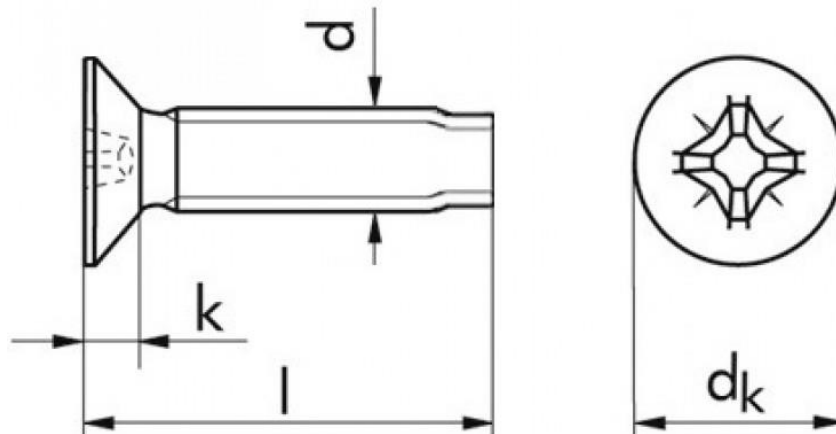

d	dk	k	Driver size
M2.5	4.70	1.50	1
M3	5.50	1.65	
M3.5	7.30	2.35	2
M4	8.40	2.70	
M5	9.30	2.70	3
M6	11.30	3.30	

Screw size		Material thickness		Mild steel sheet & bar		Aluminium sheet and bar, aluminium and zinc based die-castings	
Dia.	Pitch	From	To	Hole Dia.	Drill size	Hole Dia.	Drill Dia.
M2.5	0.45	0.50	2.00	2.25	2.25	2.20	2.20
		1.50	3.50	2.30	2.30	2.25	2.25
		3.00	6.50	2.35	2.35	2.30	2.30
M3	0.50	0.50	2.00	2.70	2.70	2.60	2.60
		1.50	3.50	2.75	2.75	2.70	2.70
		3.00	6.50	2.80	2.80	2.75	2.75
M3.5	0.60	0.50	2.00	3.10	3.10	3.10	3.10
		1.50	3.50	3.20	3.20	3.10	3.10
		3.00	6.50	3.20	3.20	3.20	3.20
		6.00	8.00	3.30	3.30	3.20	3.20
		8.00	12.00	3.30	3.30	3.20	3.20
M4	0.70	0.50	2.00	3.60	3.60	-	-
		1.50	3.50	3.70	3.70	3.60	3.60
		3.00	6.50	3.70	3.70	3.70	3.70
		6.00	8.00	3.80	3.80	3.70	3.70
		8.00	12.00	3.80	3.80	3.70	3.70
M5	0.80	1.50	3.50	4.50	4.50	4.50	4.50
		3.00	6.50	4.60	4.60	4.50	4.50
		6.00	8.00	4.70	4.70	4.60	4.60
		8.00	12.00	4.70	4.70	4.70	4.70
M6	1.00	1.50	3.50	5.40	5.40	5.40	5.40
		3.00	3.50	5.50	5.50	5.40	5.40
		6.00	8.00	5.60	5.60	5.50	5.50
		8.00	12.00	5.70	5.70	5.60	5.60
M8	1.25	1.50	3.50	7.30	7.30	7.30	7.30
		3.00	6.50	7.40	7.40	7.30	7.30
		6.00	8.00	7.50	7.50	7.40	7.40
		8.00	12.00	7.60	7.60	7.50	7.50
M10	1.50	3.00	6.50	9.20	9.20	9.20	9.20
		6.00	8.00	9.30	9.30	9.20	9.20
		8.00	12.00	9.40	9.40	9.30	9.30

All dimension's in mm